

SFC Female Connector

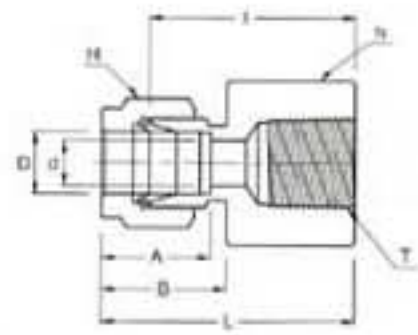

Connects Fractional Tubes To Male NPT Thread

Part No.	Tube O.D. D	T* (NPT)	d Min	Width Across Flat		A	B	I	L
				h	H				
SFC 2- 2N	1/8	1/8	2.28	9/16	7/16	12.70	15.24	22.09	28.70
SFC 2- 4N	1/8	1/4	2.28	3/4	7/16	12.70	15.24	26.92	33.52
SFC 3- 2N	3/16	1/8	3.04	9/16	1/2	13.71	16.00	23.11	29.71
SFC 4- 2N	1/4	1/8	4.82	9/16	9/16	15.24	17.78	23.87	31.24
SFC 4- 4N	1/4	1/4	4.82	3/4	9/16	15.24	17.78	28.44	35.81
SFC 4- 6N	1/4	3/8	4.82	7/8	9/16	15.24	17.78	30.22	37.59
SFC 4- 8N	1/4	1/2	4.82	1-1/16	9/16	15.24	17.78	35.05	42.41
SFC 5- 2N	5/16	1/8	6.35	9/16	5/8	16.25	18.54	24.63	32.00
SFC 5- 4N	5/16	1/4	6.35	3/4	5/8	16.25	18.54	29.46	36.83
SFC 6- 2N	3/8	1/8	7.11	5/8	11/16	16.76	19.30	25.40	32.76
SFC 6- 4N	3/8	1/4	7.11	3/4	11/16	16.76	19.30	30.22	37.59
SFC 6- 6N	3/8	3/8	7.11	7/8	11/16	16.76	19.30	31.75	39.11
SFC 6- 8N	3/8	1/2	7.11	1-1/16	11/16	16.76	19.30	36.57	43.94
SFC 6-12N	3/8	3/4	7.11	1-5/16	11/16	16.76	19.30	40.38	47.75
SFC 8- 4N	1/2	1/4	10.41	13/16	7/8	22.86	21.84	30.22	40.38
SFC 8- 6N	1/2	3/8	10.41	7/8	7/8	22.86	21.84	31.75	41.91
SFC 8- 8N	1/2	1/2	10.41	1-1/16	7/8	22.86	21.84	36.57	46.73
SFC 8-12N	1/2	3/4	10.41	1-5/16	7/8	22.86	21.84	38.10	48.26
SFC10- 6N	5/8	3/8	12.70	15/16	1	24.38	21.84	31.75	41.91
SFC10- 8N	5/8	1/2	12.70	1-1/16	1	24.38	21.84	36.57	46.73
SFC12- 8N	3/4	1/2	15.74	1-1/16	1-1/8	24.38	21.84	36.57	46.73
SFC12-12N	3/4	3/4	15.74	1-5/16	1-1/8	24.38	21.84	38.10	48.26
SFC14-12N	7/8	3/4	18.28	1-5/16	1-1/4	25.90	21.84	39.62	49.78
SFC16-12N	1	3/4	22.35	1-3/8	1-1/2	31.24	26.41	41.14	53.34
SFC16-16N	1	1	22.35	1-5/8	1-1/2	31.24	26.41	50.03	62.23

* ISO Tapered Threads are available upon request

SFC Female Connector

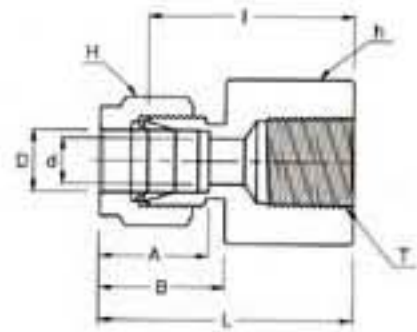

Connects Metric Tubes To Male ISO Tapered Thread

Part No.	Tube O.D. D	T* R(PT)	d Min	Width Across Flat		A	B	I	L
				h	H				
SFC 3M- 2R	3	1/8	2.4	14	12	12.9	15.3	22.1	28.7
SFC 3M- 4R	3	1/4	2.4	19	12	12.9	15.3	26.9	33.5
SFC 4M- 2R	4	1/8	2.4	14	12	13.7	16.1	23.1	29.7
SFC 6M- 2R	6	1/8	4.8	14	14	15.3	17.7	23.9	31.3
SFC 6M- 4R	6	1/4	4.8	19	14	15.3	17.7	28.4	35.8
SFC 6M- 6R	6	3/8	4.8	22	14	15.3	17.7	30.2	37.6
SFC 6M- 8R	6	1/2	4.8	27	14	15.3	17.7	35.1	42.5
SFC 8M- 2R	8	1/8	6.4	15	16	16.2	18.6	24.6	32.1
SFC 8M- 4R	8	1/4	6.4	19	16	16.2	18.6	29.5	37.0
SFC 8M- 6R	8	3/8	6.4	22	16	16.2	18.6	31.0	38.5
SFC 8M- 8R	8	1/2	6.4	27	16	16.2	18.6	35.8	43.3
SFC10M- 2R	10	1/8	7.9	18	19	17.2	19.5	25.4	33.0
SFC10M- 4R	10	1/4	7.9	19	19	17.2	19.5	30.2	37.8
SFC10M- 6R	10	3/8	7.9	22	19	17.2	19.5	31.8	39.4
SFC10M- 8R	10	1/2	7.9	27	19	17.2	19.5	36.6	44.2
SFC12M- 2R	12	1/8	8.3	22	22	22.8	22.0	25.4	35.5
SFC12M- 4R	12	1/4	9.5	22	22	22.8	22.0	30.2	40.3
SFC12M- 6R	12	3/8	9.5	22	22	22.8	22.0	31.8	41.9
SFC12M- 8R	12	1/2	9.5	27	22	22.8	22.0	36.6	46.7
SFC12M-12R	12	3/4	9.5	35	22	22.8	22.0	38.9	49.0
SFC15M- 8R	15	1/2	11.9	27	25	24.4	22.0	36.6	46.7
SFC16M- 8R	16	1/2	12.7	27	25	24.4	22.0	36.8	46.9
SFC20M- 8R	20	1/2	15.9	30	32	26.0	22.0	37.8	47.9
SFC20M-12R	20	3/4	15.9	35	32	26.0	22.0	39.6	49.7
SFC22M-12R	22	3/4	18.3	35	32	26.0	22.0	39.6	49.7
SFC22M-16R	22	1	18.3	41	32	26.0	22.0	47.8	57.9
SFC25M-12R	25	3/4	21.8	35	38	31.3	26.5	41.1	53.4
SFC25M-16R	25	1	21.8	41	38	31.3	26.5	50.0	62.3

* NPT Threads are available upon request